



EAOM-19 72 x 72, Automatic Transfer Unit For Diesel Generators

- **Automatic engine start / stop**
- **Automatic shutdown on fault condition**
- **Led status and fault indication**
- **Mains voltage measurement and monitoring (Ph-Ph or Ph-N)**
- **Generator voltage and frequency measurement and monitoring**
- **Battery voltage measurement and monitoring**
- **Simple push-button controlled operation**
- **Two user configurable inputs**
- **Provides charge generator excitation current**
- **Speed sensing from alternator frequency**
- **Fully programmable**

ABOUT INSTRUCTION MANUAL

Instruction manual of EAoM-19 automatic transfer unit consists of two main sections. Explanation of these sections are below. Also, there is other section which include technical specifications of the unit. All titles and page numbers in instruction manual are in “**CONTENTS**” section. User can reach to any title with page number.

Installation:

In this section, physical dimensions of the unit, panel mounting, electrical connections, physical and electrical installation of the unit to the system are explained.

Operation and Parameters:

In this section, user interface of the unit, how to access to the parameters, description of parameters are explained.

Also in these sections, there are warnings to prevent serious injury while doing the physical and electrical moutage or using the unit.

Explanation of the symbols which are used in these sections are given below.



This symbol is used for security warnings. User must pay attention to these warnings.



This stmbol is used to determine the dangerous situations as a result of an electrical shock. User must pay attention to these warnings definitely.



This symbol is used to determine the important notes about functions and usage of the unit.

CONTENTS

1.INTRODUCTION.....	Page	6
1.1 GENERAL SPECIFICATIONS.....	Page	6
1.2 WARRANTY.....	Page	7
1.3 MAINTENANCE.....	Page	7
2.INSTALLATION.....	Page	8
2.1 GENERAL DESCRIPTION.....	Page	9
2.2 DIMENSIONS.....	Page	9
2.3 PANEL CUT-OUT.....	Page	10
2.4 ENVIRONMENTAL RATINGS.....	Page	11
2.5 PANEL MOUNTING.....	Page	11
2.6 INSTALLATION FIXING CLAMP.....	Page	12
2.7 REMOVING FROM THE PANEL.....	Page	12
3.ELECTRICAL CONNECTIONS.....	Page	13
3.1 TERMINAL LAYOUT AND CONNECTION INSTRUCTIONS.....	Page	13
3.2 ELEKTRICAL CONNECTION DIAGRAM.....	Page	14
3.2.1 EAOM-19 SINGLE PHASE CONNECTIONS SCHEMATIC FOR TN-C AC POWER SYSTEMS.....	Page	14
3.2.2 EAOM-19 THREE PHASE CONNECTIONS SCHEMATIC FOR TN-C AC POWER SYSTEMS.....	Page	15
3.3 TOP LABEL VIEW OF THE EAOM-19.....	Page	16
3.4 UNIT WIRING.....	Page	17
3.5 UNIT WIRING DESCRIPTION.....	Page	18
4.DEFINITION OF FRONT PANEL AND ACCESSING TO THE PARAMETERS.....	Page	19
4.1 FRONT PANEL DESCRIPTION.....	Page	19
4.2 ACCESSING TO THE OPERATOR PARAMETERS.....	Page	21
4.3 ACCESSING TO THE TECHNICIAN PARAMETERS.....	Page	23
4.4 PARAMETER LIST.....	Page	25
4.5 EXPLANATION OF PARAMETERS.....	Page	26
4.5.1 MAINS VOLTAGE CONNECTION (P00) AND DISCONNECTION LEVEL (P01), UPPER LIMIT (P02).....	Page	26
4.5.2 ALTERNATOR VOLTAGE LOWER (P03) AND UPPER LIMIT (P04), FAULT CONTROL DELAY (P20).....	Page	27
4.5.3 ALTERNATOR FREQUENCY UPPER LIMIT (P05), FAULT CONTROL DELAY (P21)....	Page	27
4.5.4 ENGINE COOLING TIME (P07).....	Page	27
4.5.5 MAINS TRANSITION DELAY (P09).....	Page	27
4.5.6 BATTERY VOLTAGE LOWER LIMIT (P11).....	Page	27
4.5.7 STOP / FUEL SOLENOID SELECTION (P13).....	Page	27
4.5.8 STOP MAGNET ENERGISED TIME (P14).....	Page	28
4.5.9 ENGINE STARTED SIGNAL (P15).....	Page	28
4.5.10 STARTING ATTEMPT DURATION(P16), NUMBER OF STARTING ATTEMPTS(P06)..	Page	28
4.5.11 CONTROL ON DELAY (P19).....	Page	29
4.5.12 CONFIGURABLE INPUTS 1 AND 2 (P22 AND P23).....	Page	29
4.5.13 HORN OUTPUT SELECTION (P24).....	Page	29
4.5.14 CHOKE TIME (P25).....	Page	29
4.5.15 GENERATOR START DELAY (P26).....	Page	30
4.5.16 OIL SENSOR SELECTION (P27).....	Page	30
4.5.17 OPERATOR PASSWORD (P28).....	Page	30
4.5.18 TECHNICIAN PASSWORD (P29).....	Page	30
5.COMMISSIONING.....	Sayfa	31
5.1 MANUAL MODE.....	Sayfa	31
5.2 AUTO MODE.....	Sayfa	32
5.3 TEST MODE.....	Sayfa	32
6.OPERATION.....	Sayfa	33
6.1 ALTERNATE DISPLAY DESCRIPTION.....	Sayfa	33
6.2 FAILURE INDICATORS DESCRIPTION.....	Sayfa	36
6.3 MODE TRANSITION.....	Sayfa	38
6.4 MANUAL START.....	Sayfa	38
6.5 MANUAL STOP.....	Sayfa	38
6.6 AUTO OPERATION.....	Sayfa	38
6.7 TEST OPERATION.....	Sayfa	38

7.FAULT FINDING.....	Page	39
8.SPECIFICATIONS.....	Page	40
9.BLOK DIAGRAM.....	Page	42
10. USER DEFINED PARAMETERS.....	Page	43
LIST-1.....	Page	43

EU DECLARATION OF CONFORMITY

Manufacturer Company Name : Emko Elektronik CO.

Manufacturer Company Address: DOSAB, Karanfil Sokak, No:6, 16369 Bursa, Turkey

The manufacturer hereby declares that the product conforms to the following standards and conditions.

Product Name : Automatic Transfer Unit For Diesel Generators

Model Number : EAOM-19

Type Number : EAOM-19

Product Category : Electrical equipment for measurement, control and laboratory use

Conforms to the following directives :

73 / 23 / EEC The Low Voltage Directive as amended by 93 / 68 / EEC

89 / 336 / EEC The Electromagnetic Compatibility Directive

Has been designed and manufactured according to the following specifications

EN 61000-6-4 EMC Generic Emission Standard for the Industrial Environment

EN 61000-6-2 EMC Generic Immunity Standard for the Industrial Environment

EN 61010-1 Safety Requirements for electrical equipment for measurement, control and laboratory use

1. Introduction

1.1 General Specifications

The EAOM-19 provides for automatic transfer of a load from mains to generator in the event of a mains failure. The unit is able to detect failure of any phase of the mains and to start and switch over to a generator if the mains voltage goes outside pre-set limits. Both automatic and manual control is possible. A test mode is also available which allows the generator to be run without taking the load. The unit monitors generator operation and gives warning of any faults that are detected. It monitors:

- Mains voltage
- Alternator output (voltage and frequency)
- Engine speed
- Battery voltage
- Engine temperature
- Oil pressure

It controls:

- Engine fuel supply or engine stopping, (via external solenoid)
- Starter motor, (via external relay)
- Automatic generator start and load transfer on mains failure, (via external mains and generator contactors)
- Alarm horn

A four-digit, seven-segment display provides extensive monitoring of unit and generator parameters, including:

- Mains voltages
- Alternator voltage and frequency
- Battery voltage
- Error indication
- Program parameters

The unit is extensively programmable, with password protection on two levels. In the event that the engine fails to start on the first attempt, the attempt will be repeated a programmed number of times or until successful. If a fault is detected, the unit shuts down the engine and indicates the failure by flashing a relevant fault LED. Two user configurable inputs are included that sound an external horn, flash indicators on the panel and can be programmed to stop the engine or disconnect the load.

1.2 Warranty

EMKO Elektronik warrants that the equipment delivered is free from defects in material and workmanship. This warranty is provided for a period of two years. The warranty period starts from the delivery date. This warranty is in force if duty and responsibilities which are determined in warranty document and instruction manual performs by the customer completely.

1.3 Maintenance

If the device is used with conditions which are explained in this instruction manual, there is no need to do periodic maintenance.

2. Installation



Before beginning installation of this product, please read the instruction manual and warnings below carefully.

In package,

- One piece unit
- Two pieces fixing clamp
- One piece instruction manual

A visual inspection of this product for possible damage occurred during shipment is recommended before installation. It is your responsibility to ensure that qualified mechanical and electrical technicians install this product.

If there is danger of serious accident resulting from a failure or defect in this unit, power off the system and separate the electrical connection of the device from the system.

The unit is normally supplied without a power switch or a fuse. Use power switch and fuse as required.

Be sure to use the rated power supply voltage to protect the unit against damage and to prevent failure.

Keep the power off until all of the wiring is completed so that electric shock and trouble with the unit can be prevented.

Never attempt to disassemble, modify or repair this unit. Tampering with the unit may result in malfunction, electric shock or fire.

Do not use the unit in combustible or explosive gaseous atmospheres.

During the equipment is putted in hole on the metal panel while mechanical installation some metal burrs can cause injury on hands, you must be careful.

Montage of the product on a system must be done with it's fixing clamps. Do not do the montage of the device with in appropriate fixing clamp. Be sure that device will not fall while doing the montage.

2.1 General Description

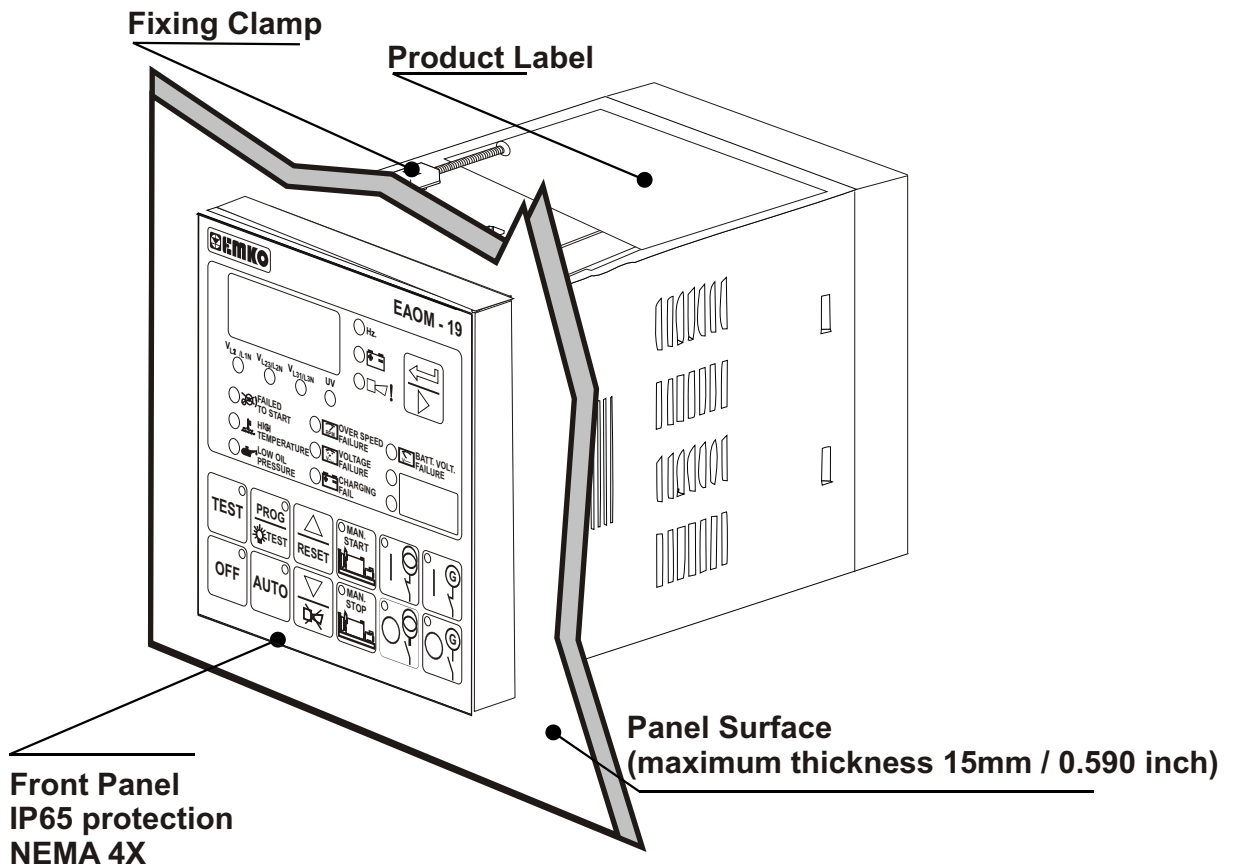

2.2 Dimensions

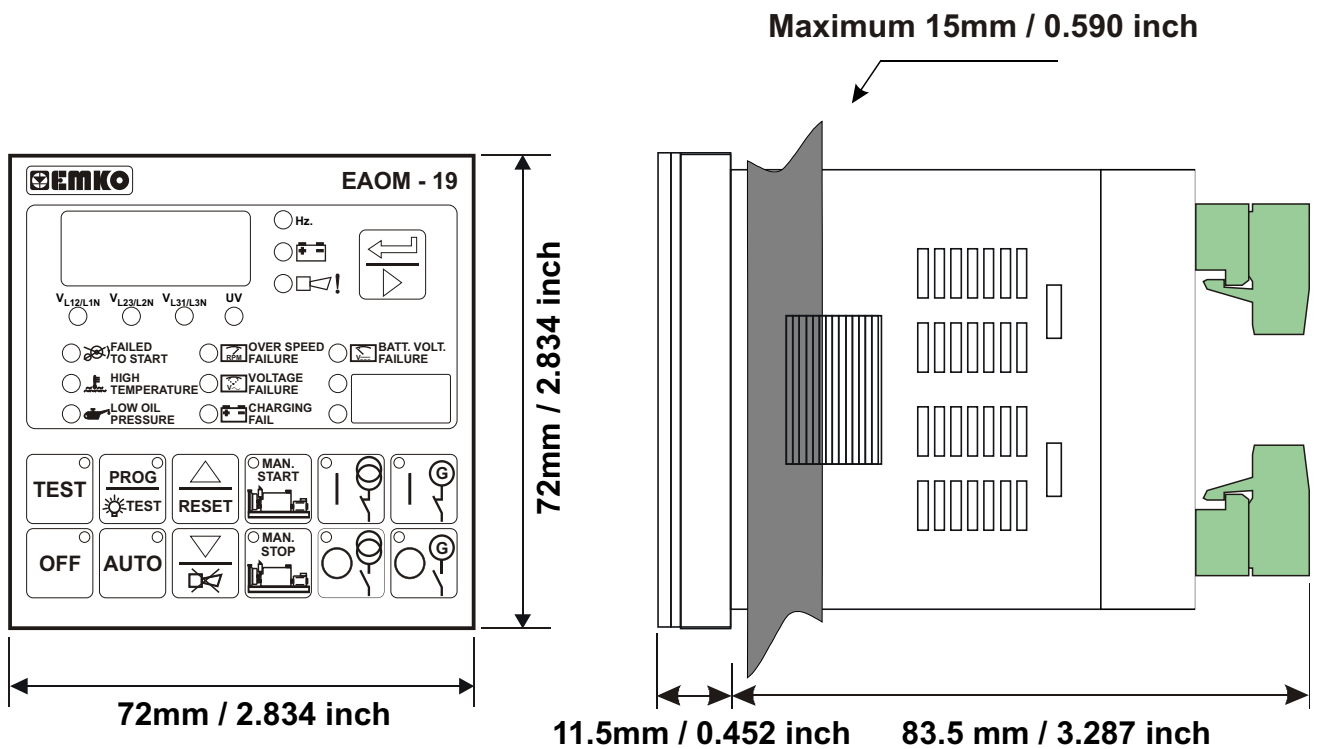

2.3 Panel Cut-Out

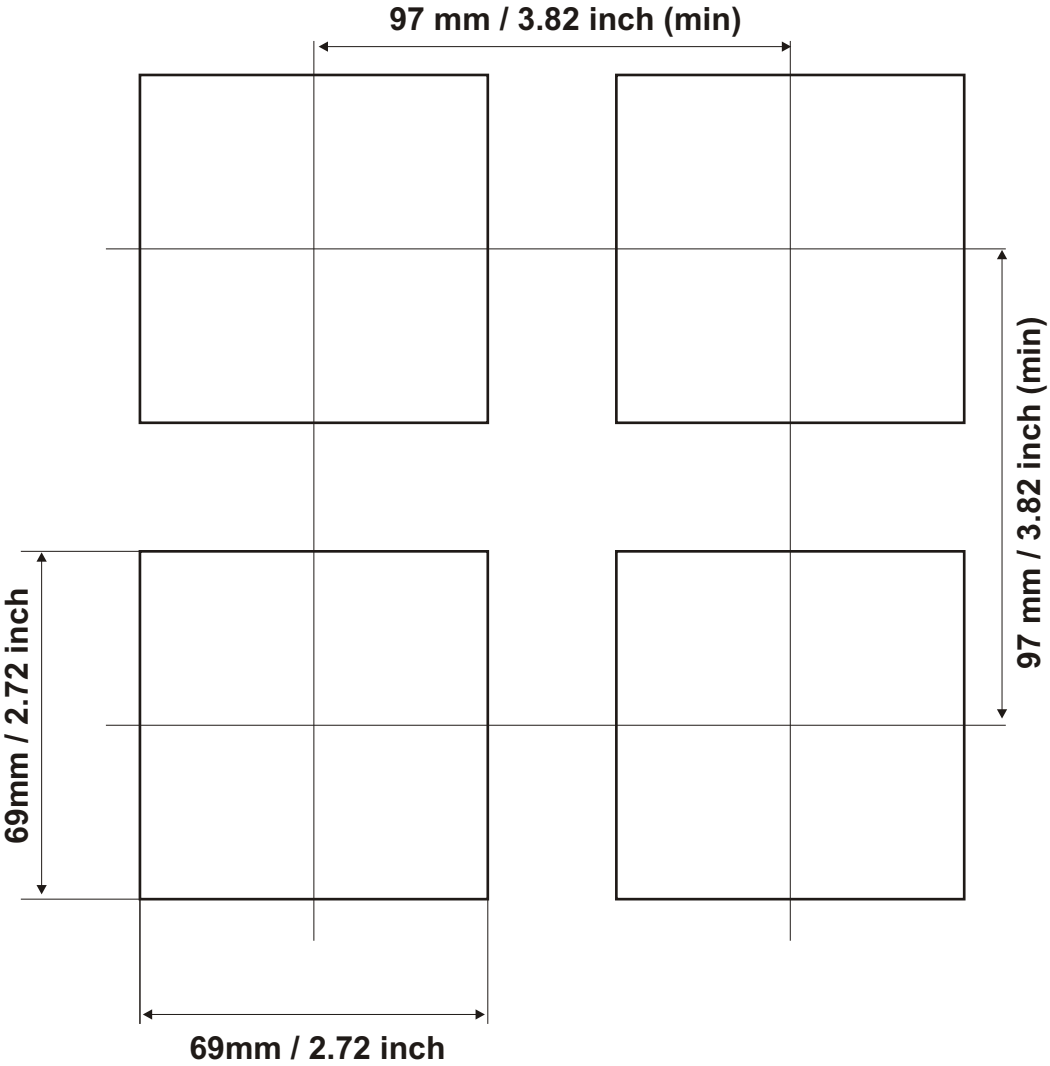

2.4 Environmental Ratings

Operating Conditions



Operating Temperature : -25°C to +70 °C



Max. Operating Humidity : %90 Rh (non-condensing)



Altitude : Up to 2000m.



Forbidden Conditions:

Corrosive atmosphere

Explosive atmosphere

Home applications (The unit is only for industrial applications)

2.5 Panel Mounting

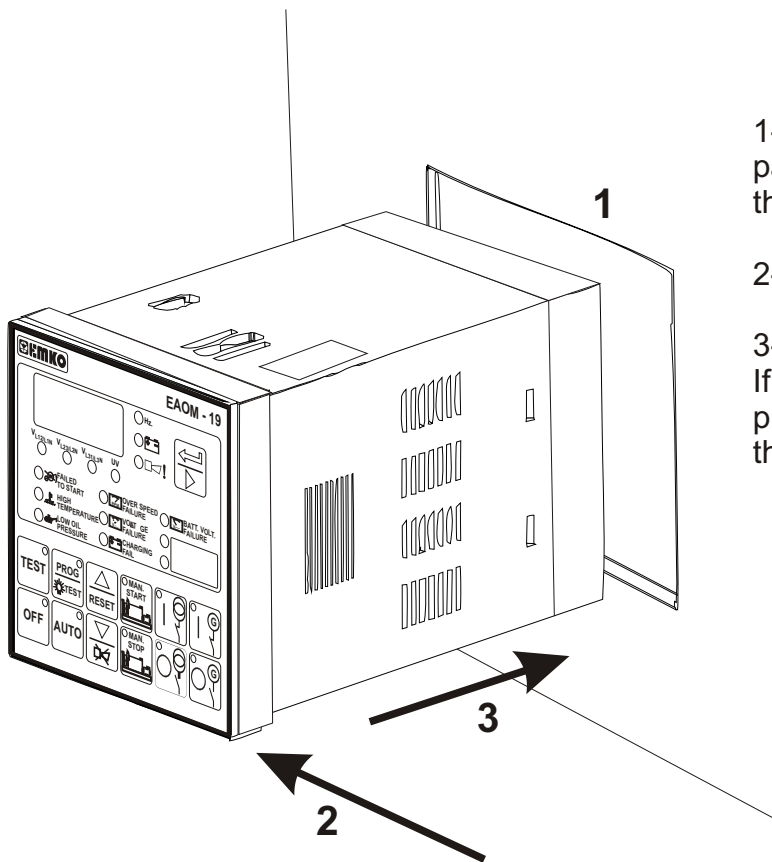

1-Before mounting the controller in your panel, make sure that the cut-out is of the right size.

2-Check front panel gasket position

3-Insert the device through the cut-out. If the mounting clamps are on the unit, put out them before inserting the unit to the panel.



During installation into a metal panel, care should be taken to avoid injury from metal burrs which might be present. The equipment can loosen from vibration and become dislodged if installation parts are not properly tightened. These precautions for the safety of the person who does the panel mounting.

2.6 Installation Fixing Clamp

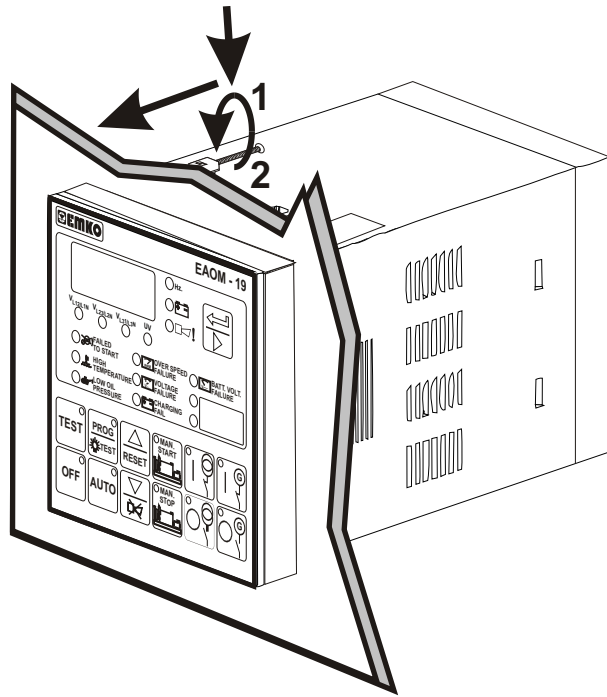

The unit is designed for panel mounting.

1-Insert the unit in the panel cut-out from the front.

2-Insert the mounting clamp from the rear side of the device and tighten the fixing screws to secure the unit against the panel.



Montage of the device to a system must be done with it's own fixing clamps. Do not do the montage of the device with inappropriate fixing clamps. Be sure that device will not fall while doing the montage.

2.7 Removing from the Panel



Before starting to remove the device from panel, power off the device and the related system.

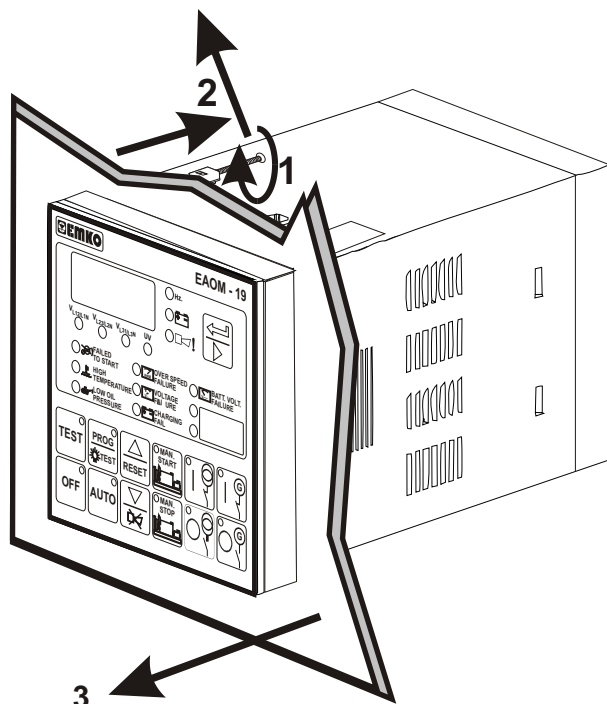

1-Loosen screws.

2-Lift the locking tabs located on both the right and left hand sides and pull the fixing clamp from the device while holding the unit in place.

3-Pull the unit through the front of the panel

3. Electrical Connections



You must ensure that the unit is correctly configured for your application. Incorrect configuration could result in damage to the process being controlled, and/or personal injury. It is your responsibility, as the installer, to ensure that the configuration is correct.

Parameters of the unit has factory default values. These parameters must be set according to the system's needs.



Only qualified personnel and technicians trained specially should work on this equipment. This equipment contains internal circuits with voltage dangerous to human life. There is severe danger for human life in the case of unauthorized intervention.



Be sure to use the rated power supply voltage to protect the unit against damage and to prevent failure.



Keep the power off until all of the wiring is completed so that electric shock and trouble with the unit can be prevented.

3.1 Terminal Layout and Connection Instructions

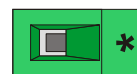
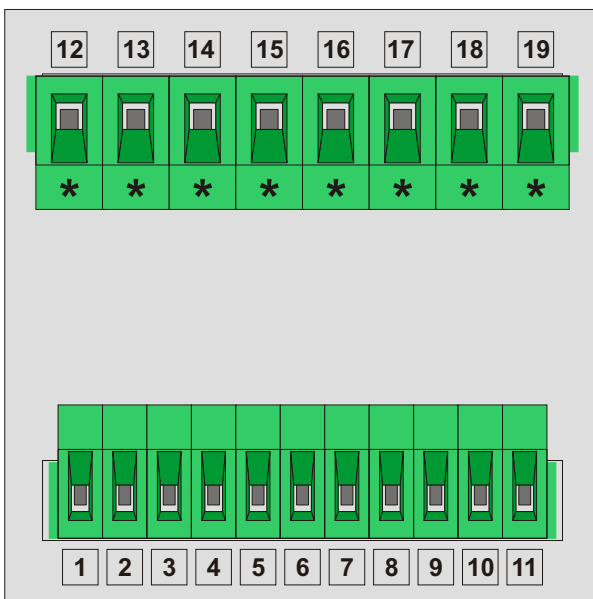

8 pieces



7.62mm



11 pieces



5.08mm

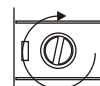

Torque 0.5 Nm



Screw driver 0.8x3mm

3.2 Electrical Connection Diagram

3.2.1 EAOM-19 Single Phase Connections Schematic For TN-C AC Power Systems

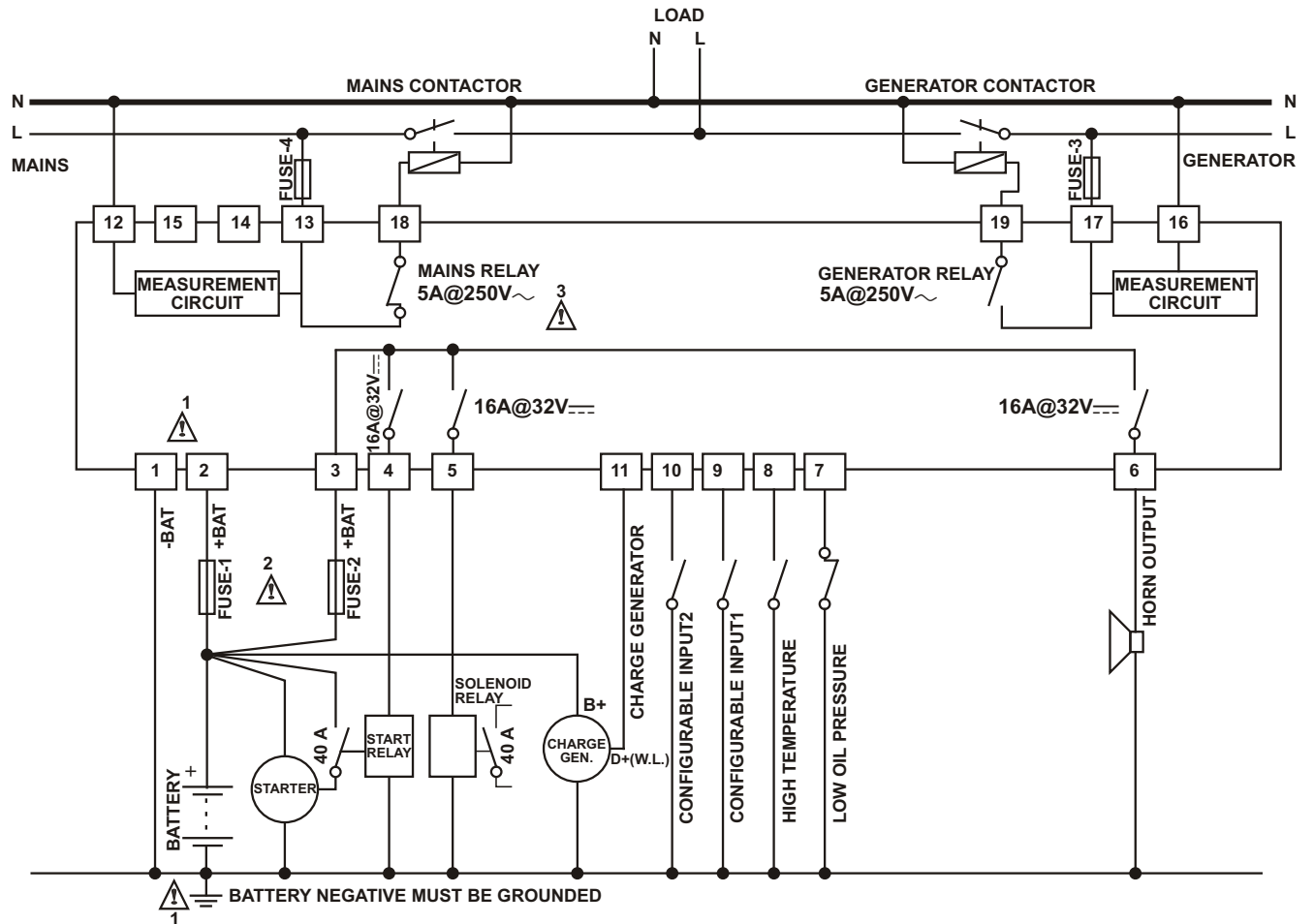

3.2.2 EAOM-19 Three Phase Connections Schematic For TN-C AC Power Systems

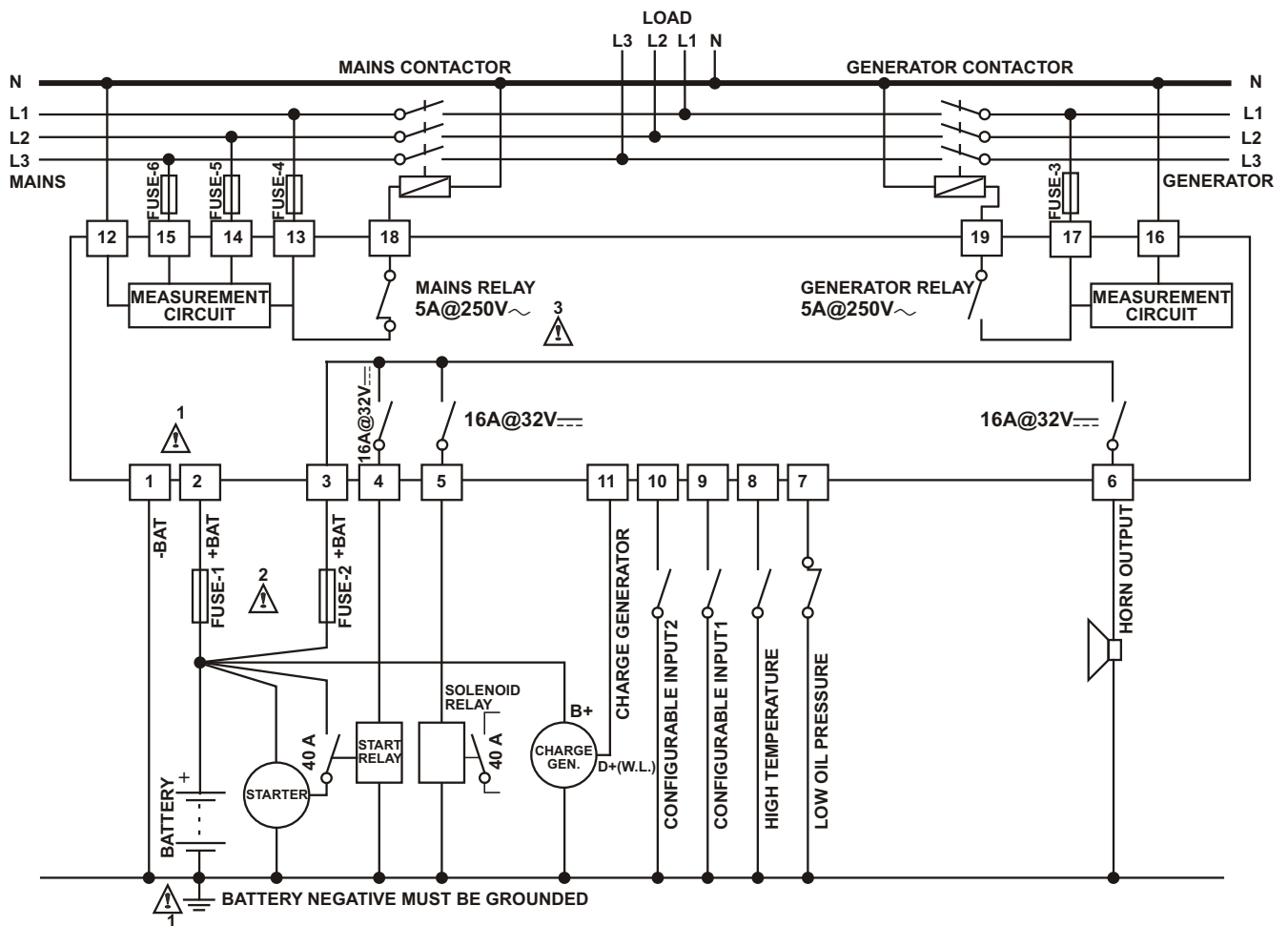

1-  Connect the unit as shown in the appropriate diagram, Section 3.2.1 or 3.2.2. Ensure the battery supply is of the correct polarity, and that the battery negative rail is grounded. The connectors can be unplugged from the rear of the unit for convenience and to speed up installation.

2-  The fuses should be as follows:

FUSE 1	1A. T
FUSE 2	According to current required by solenoids etc.
FUSES 3,4	Max. 5A.
FUSES 5,6	1A.

3-  ~ Symbol means Vac,
 == Symbol means Vdc

3.3 Top Label View Of The EAOM-19

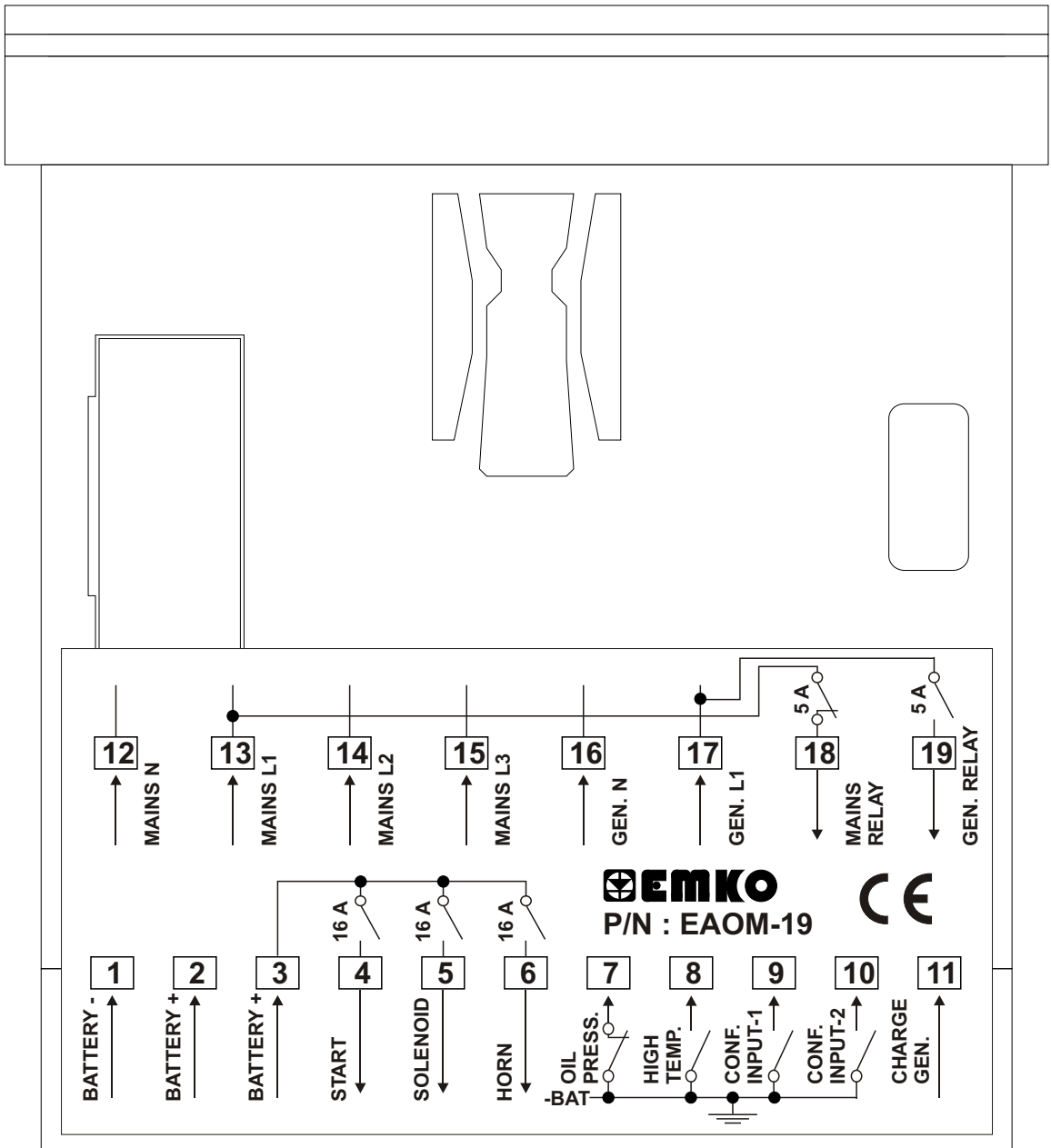

3.4 Unit Wiring

Table 3.1 shows the connections and recommended cable sizes. Table 3.2 describes the functions of the connections.

Pin	Description	Cable Size (mm ²)	Notes
1	- Battery supply to EAOM-19	1.0	Supplies to unit
2	+ Battery supply to EAOM-19	1.0	Supplies to unit
3	+ Battery supply input	2.5	Supplies to Pin 4,5,6.
4	Output to start relay	2.5	16 A. Max +DC supply from PIN3
5	Output to Fuel / Stop Solenoid	2.5	16 A. Max +DC supply from PIN3
6	Output to horn	2.5	16 A. Max +DC supply from PIN3
7	Input from oil pressure switch	1.0	Switch to "0" Volt
8	Input from temperature switch	1.0	Switch to "0" Volt
9	Configurable failure input-1	1.0	Switch to "0" Volt
10	Configurable failure input-2	1.0	Switch to "0" Volt
11	Input from charge generator	1.0	
12	Mains voltage neutral	1.0	
13	Mains voltage input (L1)	1.0	
14	Mains voltage input (L2)	1.0	3 phase only
15	Mains voltage input (L3)	1.0	3 phase only
16	Generator voltage neutral	1.0	
17	Generator voltage input (L1)	1.0	
18	Mains contactor	2.5	Relay output (5A)
19	Generator contactor	2.5	Relay output (5A)

Table 3.1 Unit Wiring

3.5 Unit Wiring Description

Pin	Function	
1	Negative battery input supplies EAOM-19.	
2	Positive battery input supplies EAOM-19.	
3	Battery positive input. Supplies Pin 4,5 and 6.	
4	Output to Start relay. +DC supply from pin 3. Controls starter motor.	
5	Output to Fuel/Stop solenoid. +DC supply from pin 3. Controls fuel to engine or controls engine stopping	
6	Output to horn. +DC supplies from pin 3. Alarm output.	
7	Input from Oil Pressure switch. The oil pressure switch must be the type that opens when oil pressure is normal, and closes on low oil pressure. (failure condition or engine stopped.)	
8	Input from Temperature switch. Switched to 0V, when engine temperature exceeds thermostat setting.	
9	Configurable input-1. Normally open. When switched to 0V, sounds the horn and flashes SPARE-1 LED on panel. Can be programmed to stop the engine or de-energise the generator contactor.	
10	Configurable input-2. Normally open. When switched to 0V, sounds the horn and flashes SPARE-2 LED on panel. Can be programmed to stop the engine or de-energise the generator contactor.	
11	Input from charge generator. Can be used to detect when engine has started. Must be connected to +BAT if not used.	
12	Mains voltage neutral.	
13	L1	Mains voltage inputs. Used to detect failure for controlling automatic transfer of load to generator. Pins 14 and 15 not used on single phase applications.
14	L2	
15	L3	
16	Generator voltage neutral.	
17	Input from generator L1 phase. Unit can be programmed to use frequency of alternator output to detect when engine has started.	
18	Mains contactor. Relay output (NC).	
19	Generator contactor. Relay output (NO).	

Table 3.2 Unit Wiring Description

4. Definition Of Front Panel And Accessing To The Parameters

4.1 Front Panel Description

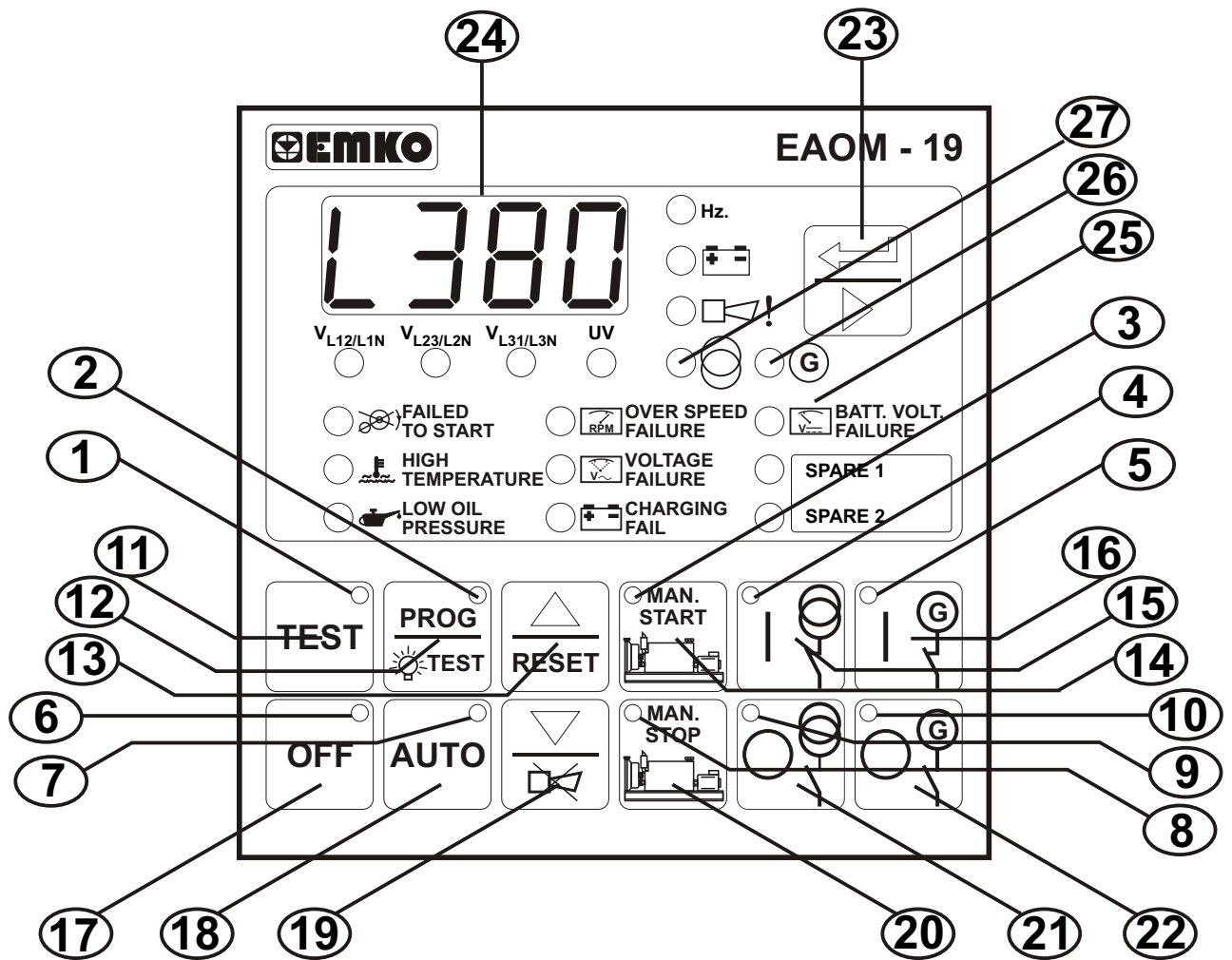

Number	Comment
1	The LED shows the Unit is in TEST position. It's colour is red. The LED light off the unit is in other than TEST position.
2	The red LED shows the EAOM-19 is in the Programming Mode. The LED is lit when the unit is in the Programming Mode, lit lights off when the unit is in the other modes.
3	In the MANUAL, AUTO and TEST modes the LED (3) lights on when the engine is in the start position. LED' s colour is green.
4	The LED shows the load is connected to the mains. It's colour is green.
5	The LED shows the load is supplied from the generator. It's colour is green. If this LED is lit that the generator contactor is closed and the load is supplied from the generator.
6	The LED shows the unit is in OFF position. It's colour is red. The LED light off the unit is in other than OFF position.
7	The LED shows the Unit is in AUTO position. It's colour is red. The LED light off the unit is in other than AUTO position.
8	In the MANUAL, AUTO and TEST modes the LED (8) lights on when the engine is stop position. LED' s colours is red.
9	The LED shows the load isn't connected to the mains. It's colour is red.
10	The LED shows the load isn't connected to the generator. It's colour is red.

Number	Comment
11	The button is used for changing operating mode of the unit to the TEST Mode. The unit changes operating mode to the TEST Mode and LED (1) is lit when this button is pressed.
12	The LAMP TEST function of the unit is operated and entered in the Programming Mode by using this button. The LAMP TEST function operates when the button is pressed first. When the button is pressed and keeping pressed for 5 seconds the unit is passed to the PROGRAMMING Mode and LED (2) is lit at the same time.
13	It runs as INCREMENT and FAILURE RESET button. The button, in the normal conditions runs for FAILURE RESET purpose when any failure is detected, it works increasing values of parameters in PROGRAMMING Mode.
14	The button used for starting the engine when the unit is in the MANUAL Mode. The LED (3) is lit when the button is pressed. It is only active when the unit is in MANUAL Mode.
15	The button is used for transferring the load to the mains only in MANUAL mode.
16	The button is used for transferring the load to the generator. It is active only in Manual Mode.
17	The button is used for changing operating mode of the unit to the OFF Mode. The unit changes operating mode to the OFF Mode and LED (6) is lit when this button is pressed.
18	The button is used for changing operating mode of the unit to the AUTO Mode. The unit changes operating mode to the AUTO Mode and LED (7) is lit when this button is pressed.
19	It runs as HORN SILENCE and DECREMENT button. The button, in the normal conditions runs for HORN SILENCE if the horn is running purpose when any failure is detected, it works decreasing values of parameters in PROGRAMMING Mode.
20	The button is used for stopping the engine when the unit is in the MANUAL Mode. The LED (8) is lit when the button is pressed. It is only active when the unit is in MANUAL Mode.
21	The button is used for disconnecting the load from the mains. It is only active when the unit is in MANUAL Mode.
22	The button is used for disconnecting the load from the generator. It is only active when the unit is in MANUAL Mode.
23	Alternate Display Mode Button. It is used for rotating between parameters and approving of the values, of the unit and displays. See section 4 and Section 6.1
24	Multi Function Display. It is used for Programming the Unit and features explained in section 6.
25	Failure Indicators. Detailed information about this subject is explained in section 6.2.
26	Generator voltage okay led.
27	Mains voltage okay led.

4.2 Accessing To The Operator Parameters

Programming can be carried out only while the unit is in **OFF** mode. Press the OFF (17) button. If the engine is running, it will stop and the LED (6) lights on. Then proceed as follows:

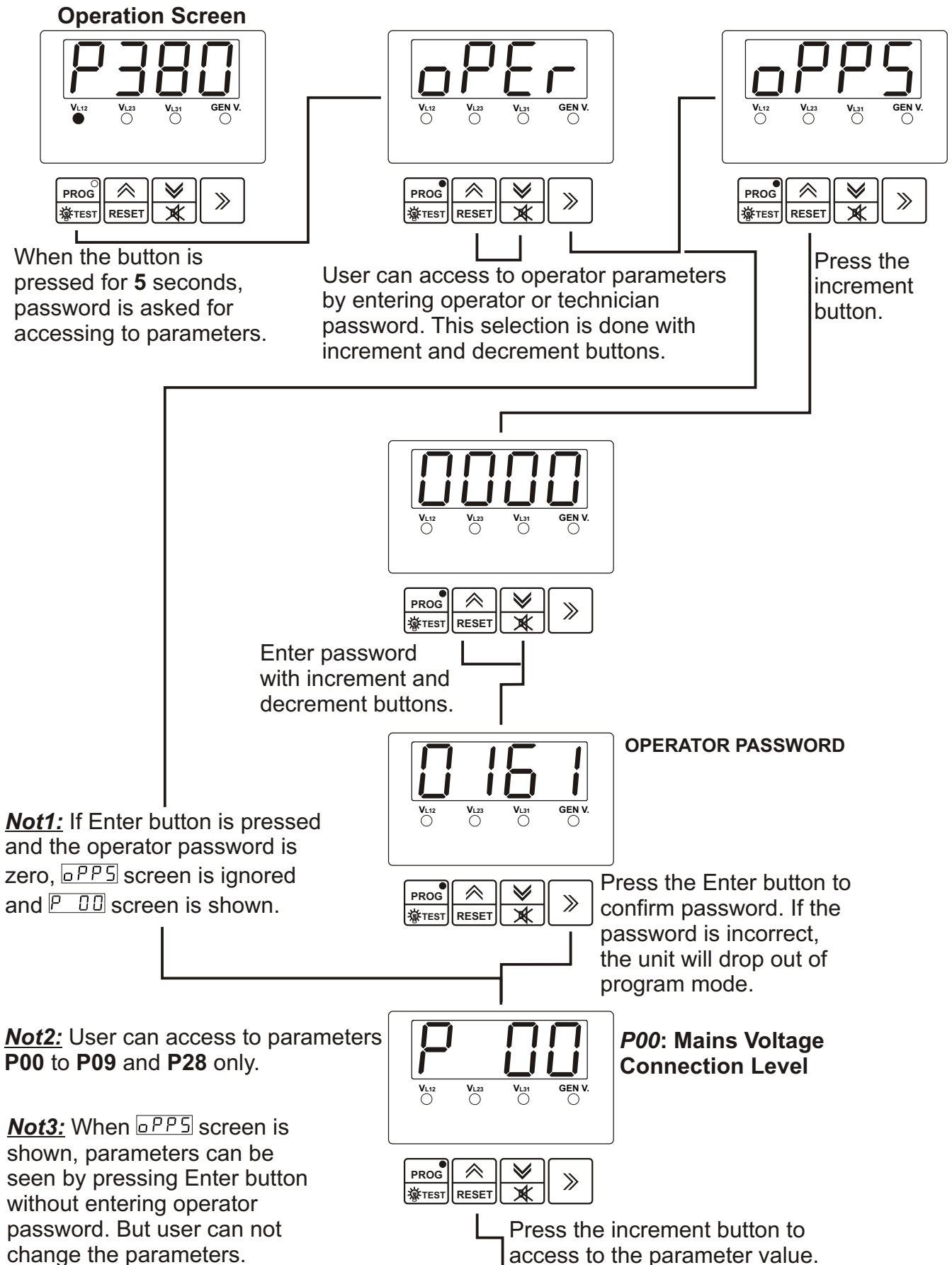

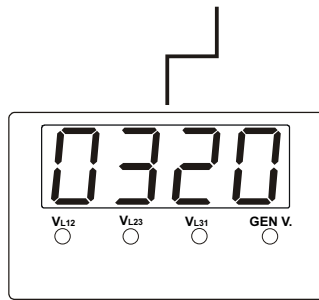

The value of parameter **P00**



Change the parameter value with increment and decrement buttons.

Press Enter button to confirm the changed value or access the following parameter.

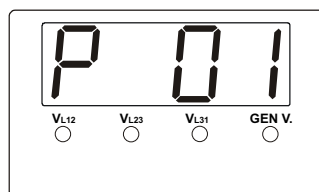

P01: Mains Voltage Disconnection Level



To exit the programming mode, press the PROG button.

User can access to the following parameter by pressing Enter button.

Press the increment button to access to the parameter value.

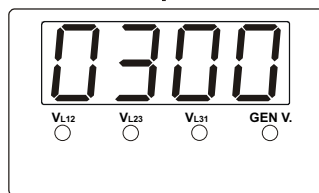

The value of parameter **P01**



Change the parameter value with increment and decrement buttons.

Press Enter button to confirm the changed value or access the following parameter.

Operation Screen

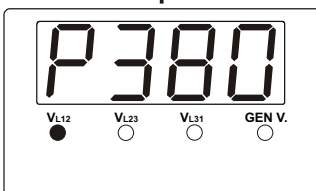

P02: Mains Voltage Upper Limit



User can access to the following parameter by pressing Enter button. On this way user can access to parameters **P00** to **P09** and **P28** only.



IF NO KEYS ARE PRESSED FOR A PERIOD OF 2 MINUTES, THE UNIT WILL RETURN TO THE NORMAL OPERATION SCREEN.

4.3 Accessing To The Technician Parameters

Programming can be carried out only while the unit is in **OFF** mode. Press the OFF (17) button. If the engine is running, it will stop and the LED (6) lights on. Then proceed as follows:

Operation Screen

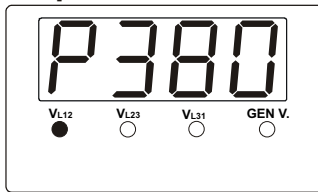

When the button is pressed for **5** seconds, password is asked for accessing to parameters.

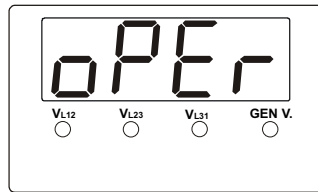

User can access to technician parameters by entering technician password. This selection is done with increment and decrement buttons.

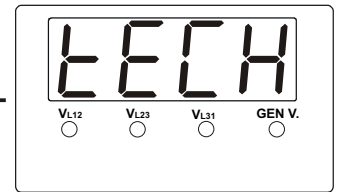

Press the Enter button.

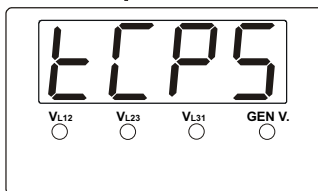

Press the increment button.

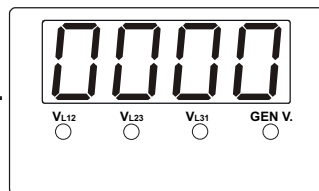

Enter password with increment and decrement buttons.

Not1: If Enter button is pressed and the technician password is zero, **EEPS** screen is ignored and **P 00** screen is shown.

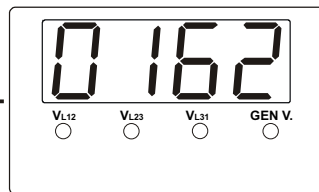

TECHNICIAN PASSWORD



Press the Enter button to confirm password. If the password is incorrect, the unit will drop out of program mode.

Not2: User can access to all parameters (**P00 to P29**).

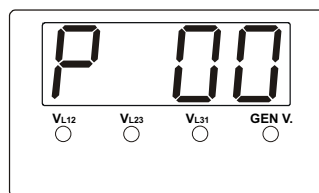

P00: Mains Voltage Connection Level



Press the increment button to access to the parameter value.

Not3: When **EEPS** screen is shown, parameters can be seen by pressing Enter button without entering operator password. But user can not change the parameters.

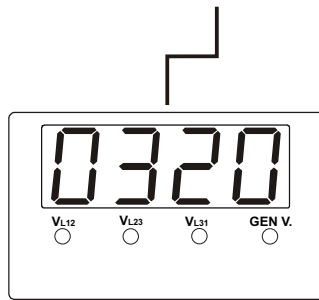

The value of parameter **P00**



Change the parameter value with increment and decrement buttons.

Press Enter button to confirm the changed value or access the following parameter.

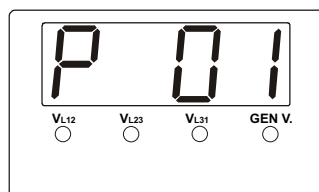

P01: Mains Voltage Disconnection Level

To exit the programming mode, press the PROG button.



User can access to the following parameter by pressing Enter button.

Press the increment button to access to the parameter value.

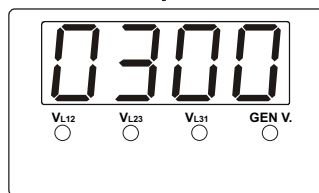

The value of parameter **P01**



Change the parameter value with increment and decrement buttons.

Press Enter button to confirm the changed value or access the following parameter.

Operation Screen

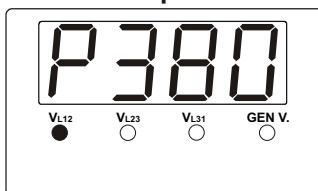

P02: Mains Voltage Upper Limit



User can access to the following parameter by pressing Enter button. On this way user can access to all parameters (**P00 to P29**).



IF NO KEYS ARE PRESSED FOR A PERIOD OF 2 MINUTES, THE UNIT WILL RETURN TO THE NORMAL OPERATION SCREEN.

4.4 Parameter List

Prm. No.	Definition of Parameter	Unit	Lower / Upper Limit	Default		
P00	Mains voltage connection level	VAC	60 - 600	320		
P01	Mains voltage disconnection level	VAC	60 - 600	300		
P02	Mains voltage upper limit	VAC	60 - 600	440		
P03	Alternator voltage lower limit	VAC	60 - 600	320		
P04	Alternator voltage upper limit	VAC	60 - 600	440		
P05	Speed upper limit	Hz.	30.0 - 75.0	53.0		
P06	Number of starting attempts	Number	1 - 10	3		
P07	Engine cooling time	Minute	0 - 99	3		
			0 = disables cooling process			
P08	Horn duration	Second	0 - 999	60		
			0 = continuous			
P09	Mains transition delay	Minute	0 - 30	3		
P10	Single / Three phase selection	Select	1 PH / 3 PH	3 PH		
P11	Battery voltage lower limit	VDC	7.2 - 24.0	8.0		
P12	Mains-Generator or Generator-Mains change over delay	Second	0.1 - 25.0	1.0		
P13	Stop / Fuel solenoid selection	Select	StoP / FuEL	FuEL		
P14	Stop magnet energising time	Second	0 - 99	20		
P15	Engine started signal		Select			
	P15.0	Charge generator			no / YES	YES
	P15.1	Speed			no / YES	No
	P15.2	Alternator voltage			no / YES	YES
P15.3	Oil pressure		no / YES	No		
P16	Starting attempt duration	Second	5 - 99	5		
P17	Alternator voltage limit for crank disconnection	VAC	40 - 360	300		
P18	Speed limit for crank disconnection	Hz.	20.0 - 45.0	40.0		
P19	Control on delay	Second	0 - 99	10		
P20	Alternator voltage fault control delay	Second	0.0 - 10.0	5.0		
P21	Speed fault control delay	Second	0.0 - 10.0	5.0		
P22	Configurable failure input-1 (Pin9)		Number	0 - 6	0	
	0	LED flashes and horn sounds. It is unlatched.				
	1	LED flashes and horn sounds and then stays on until reset.				
	2	As "1" plus engine stops.				
	3	As "0" but only while engine running.				
	4	As "1" but only while engine running.				
	5	As "4" plus engine stops if running.				
6	As "4" plus generator contactor de-energised , if engine running.					
P23	Configurable failure input-2 (Pin10) The same as P22	Number	0 - 6	0		
P24	Horn output selection	Number	0 - 1	0		
P25	Choke time	Second	0.0 - 10.0	0.8		
P26	Generator start delay	Second	0 - 9999	0		
P27	Oil sensor selection	Number	0 - 1	0		
P28	Operator password (P00 to P09, and P28)	Number	0 - 9999	0		
P29	Technician password (P00 to P29)	Number	0 - 9999	0		

4.5 Explanation of Parameters

4.5.1 Mains Voltage Connection(P00) and Disconnection Level(P01), Upper Limit(P02)

P00 Mains voltage connection level

P01 Mains voltage disconnection level

P02 Mains voltage upper limit

In Automatic mode, the unit uses these parameters to decide when to switch the load between the mains supply and the generator. If the mains voltage is higher than the Upper Limit or lower than the Disconnection Level, the unit connects the load to the generator instead of to the mains. If the load is running on the mains and the mains voltage falls, the unit will switch the load to the generator when the mains voltage falls below the Disconnection Level. Conversely, if the mains voltage is low and the load is running on the generator, the unit will not restore the mains supply to the load until the mains voltage reaches the Connection Level. This hysteresis prevents constant switching between mains and generator as the mains varies about the switching levels. Figure 4.1 shows how, in automatic mode, the load is transferred between mains and generator as the mains voltage varies over time.

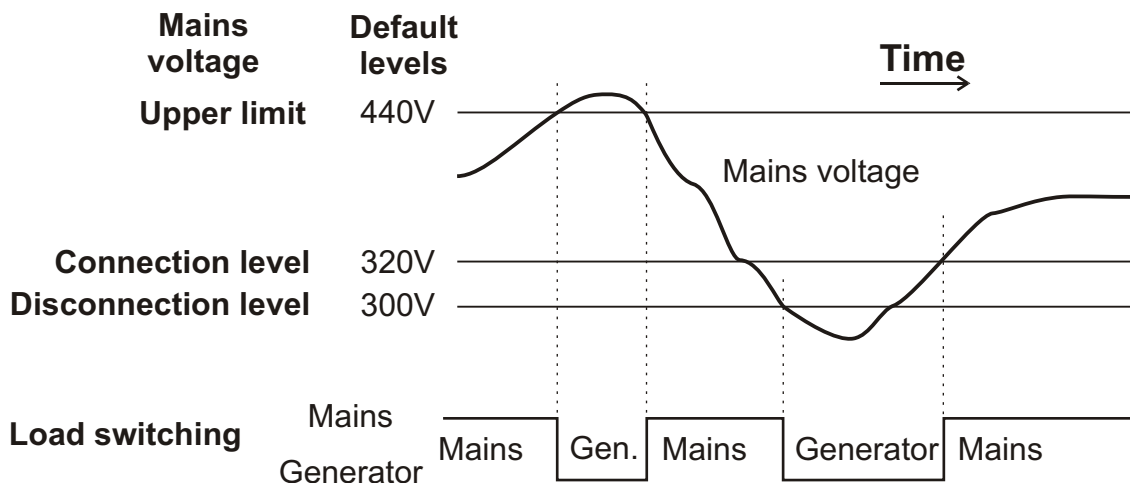

Figure 4.1 Load Switching Levels

4.5.2 Alternator Voltage Lower(P03) and Upper Limit(P04), Fault Control Delay(P20)

P03 Alternator voltage lower limit
P04 Alternator voltage upper limit
P20 Alternator voltage fault control delay

At the end of **Control on delay** time defined by parameter P19, a fault will be reported if the generator voltage goes outside the window defined by the upper and lower limits for more than the time defined as the **Alternator voltage fault control delay** (P20). This failure immediately stops the generating set, without cool-down delay.

4.5.3 Alternator Frequency Upper Limit(P05), Fault Control Delay(P21)

P05 Speed upper limit
P21 Speed fault control delay

At the end of **Control on delay** time defined by parameter P19, a fault will be reported if the generator frequency exceeds the upper limit for more than the time defined as the **Speed fault control delay** (P21). This failure immediately stops the generating set, without cool-down delay.

4.5.4 Engine Cooling Time (P07)

This is the time the generator is to run off-load once the load transfer signal has ceased. This gives the engine time to cool down before shutdown. Parameter P07 **Engine cooling time** defines the duration of this cooling-off period.

4.5.5 Mains Transition Delay (P09)

In automatic mode, when the mains has been restored after an interruption, the unit will switch the load back from the generator to the mains supply after the delay programmed into P09. This delay allows time for the mains voltage to settle before reconnecting the load.

4.5.6 Battery Voltage Lower Limit (P11)

If the battery voltage drops below the defined **Battery Voltage Lower Limit**, an alarm occurs. It doesn't stop the generating set.

4.5.7 Stop / Fuel Solenoid Selection (P13)

This parameter allows the use of either a Stop solenoid or a Fuel solenoid.

With Fuel Solenoid selected, the fuel solenoid will be energised while the engine is running and de-energised to cut off the fuel and stop the engine.
With Stop Solenoid selected, the stop solenoid is normally de-energised and only energised to stop the engine. The solenoid remains energised for the period defined as the **Stop Magnet Energising Time** (P14).

4.5.8 Stop Magnet Energised Time (P14)

This parameter sets the period for which the Stop solenoid is energised to stop the engine. It applies only where parameter P13 is set to **Stop Solenoid**.

4.5.9 Engine Started Signal (P15)

The EAOM-19 must de-energise the Start solenoid, to disconnect the starter motor, once the engine is running. Conversely, if the engine does not start after the pre-set start time, the unit will turn off the starter motor and start again. Hence, the unit must be able to detect when the engine has started. Four signals are available to provide engine running information, as follows :

- 0 Charging generator energising coil current. This current should fall to zero once the engine has started.
- 1 Engine speed, as selected by parameter P18 **Speed Limit for Crank Disconnection**.
- 2 Alternator voltage, as selected by parameter P17 **Alternator Voltage Limit for Crank Disconnection**.
- 3 Oil pressure the oil pressure switch should open when the oil pressure is sufficient.

Any or all of these signals can be selected for use. It is advisable to select at least two of them preferably 1 Engine speed and either 0 Charging generator or 2 Alternator voltage.



See Section 4.5.10 . If any of the selected signals appears, the unit assumes that the engine has started.

4.5.10 Starting Attempt Duration(P16), Number Of Starting Attempts(P06)

Engine Starting:

When the EAOM-19 receives an Engine Start command, it energises the start solenoid to drive the starter motor and energises the Fuel solenoid (if selected see Section 4.5.7 Stop/Fuel Solenoid selection (P13)) to provide fuel for the engine. If the EAOM-19 detects that the engine has started, it de-energises the starter motor. Engine started signals are defined by parameter P15 Engine started signal see Section 4.5.9.

Parameter P16 **Starting attempt duration** defines the maximum period for which drive will be applied to the starter motor. It makes a new attempt after a delay equal to twice the defined **Starting attempt duration**.

Parameter P06 **Number of starting attempts** defines the number of unsuccessful tries that the EAOM-19 will make before abandoning the attempts. If all these attempts fail, EAOM-19 operations are locked out and a **Start Failure** indication is displayed. (  LED is lit) The unit remains locked until the RESET (13) button has been pressed.

4.5.11 Control On Delay (P19)

During the initial period after the engine has been started, there can be fluctuations in engine speed and alternator output that could generate spurious fault indications. Parameter P19 defines a period during which any fault indications, except High Temperature, will be ignored by the EAOM-19. Also, in the event of a mains failure, transfer of the load from mains to generator will be delayed until the end of the Control On Delay period. This period begins when the EAOM-19 has detected engine starting and has cut off the drive to the starter motor.

4.5.12 Configurable Inputs 1 and 2 (P22 and P23)

The unit can be configured to respond in any of seven different ways to each one of these inputs. A contact closure to 0V on any of these inputs causes the horn to sound for the period programmed by P08 and lights the appropriate indicator on the panel. The EAOM-19 can be programmed to respond in one of seven ways:

- 0 Indication is unlatched the LED flashes only while the input is 0V. This input has no effect if any other alarm condition is present.
- 1 Indication is latched. The LED flashes while the horn is sounding and then stays on until the RESET (13) button is pressed.
- 2 This is the same as 1 but, in addition, the engine is shut down.

Options 3...6 are effective only while the engine is running.

- 3 Indication is unlatched the LED flashes only while the input is 0V. This input operates only if the engine is running and has no effect if any other alarm condition is present.
- 4 Indication is latched. The LED flashes while the horn is sounding and then stays on until the RESET (13) button is pressed. This input operates only if the engine is running.
- 5 As 4 but, in addition, the engine is shut down.
- 6 As 4 but, in addition, the generator contactor is de-energised to disconnect the load from the generator. The engine is not shut down.

4.5.13 Horn Output Selection (P24)

This parameter determine the function of horn output(Pin 6);
0: Alarm output, 1: Choke output.

4.5.14 Choke time (P25)

This parameter sets the period for which the choke output is energised.

4.5.15 Generator Start Delay (P26)

In automatic mode, when the mains has been interrupted, the unit will start the generator after the delay programmed into P26. This can be used to prevent nuisance tripping when switching loads etc.

4.5.16 Oil Sensor Selection (P27)

This parameter determine the function of oil sensor input(Pin 7);

0: Oil level sensor.

1: Oil pressure sensor.

If it is selected as oil level sensor(0), the oil pressure parameter (P15.3) of the engine started signals will not be functional. But if it is selected as oil pressure sensor(1), the oil pressure parameter (P15.3) of the engine started signals will be functional.

4.5.17 Operator Password (P28)

Use this option to change the Operator password. This password allows access to program parameters P00 to P09 and P28.

4.5.18 Technician Password (P29)



Use this option to change the Technician password. It allows access to program parameters P00 to P29.



To prevent to changing unit program parameters by unauthorised personel don't allow to the learning operator and technician passwords by the others. In case of this situation, change passwords immediately.

5. Commissioning

5.1 Manual Mode

1. Check that the unit is correctly wired and that the wiring is of a standard and rating compatible with the system.
 2. Check that the correct fuses are fitted.
 3. Program the unit as detailed in *Section 4*.
 4. Take temporary steps to prevent the engine from starting . (for example, disable the fuel solenoid.)
 5. After a visual inspection to ensure it is safe to proceed, connect the battery supply.
 6. On the EAOM-19, press the MAN ENGINE START (14) button. At this moment the LED (3) lights on.
 7. Check that the engine start sequence commences. The starter motor should run for the programmed period (P16) for the pre-set (P06) number of times.
 8. Check that the   (Start Failure LED) flashes and the LED (3) lights off.
 9. Check the unit will change to the STOP position and the LED (8) lights on.
 10. Restore the engine to operational state (reconnect the fuel solenoid).
 11. Press the MAN ENGINE START (14) button. The LED (3) will light on.
 12. Check the start sequence, as follows:
 - the starter motor runs
 - the engine starts
 - the starter motor disengages once the engine is running.
- If not, check that the engine is fully operational (fuel available etc.) and check the wiring and programming of the EAOM-19.
13. Check that the engine runs up to its operating speed. If not and an alarm is present, check that the alarm is valid and then check the input wiring.
 14. Press the MAN ENGINE STOP (20) button. At this moment the LED (8) will light on. The engine should stop. Allow time for the engine to come to rest.

5.2 Auto Mode

1. Check that the mains is connected to the unit and is present.
2. Check the mains voltage readings on the display.
3. At the EAOM-19, press the AUTO (18) button. The LED (7) on the button should light.
4. Switch off the mains supply to the unit. Check that the generator starts and, after a delay, the load is transferred to the generator.
5. Restore the mains supply to the unit. Check that, after a delay, the load is transferred back to the mains and the generator, after a further delay, shuts down.

5.3 Test Mode

1. Check that the mains is connected to the unit.
2. Press the TEST (11) button. At this moment the LED (1) will light on.
3. Check that the generator starts and that the load is still connected to the mains.
4. Switch off the mains supply. Check that the contactors change over to connect the load to the generator. Check also that the **Auto** (7) LED is lit. The unit changes operating mode to AUTO Mode automatically.
5. Restore the mains supply. Check that the contactors reconnect the load to the mains supply.
6. Check that the generator shuts down with cool-down period.

6. Operation

6.1 Alternate Display Description

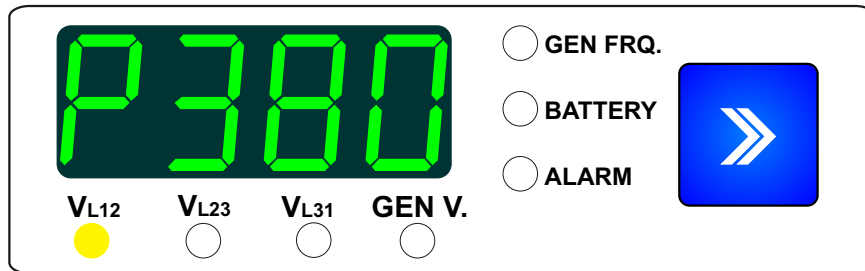

Four-digit, seven-segment LED display. This multi-function display the selected parameter from the list alongside. Use DISPLAY MODE (23) button to select which parameter is to be displayed, as indicated by the adjacent LEDs. The button selects the parameters in sequence, as follows.

Please note that phase-phase voltage readings are prefixed by 'P' while phase-neutral readings are prefixed by 'n'.

- VL12 - Mains voltage L1-L2, prefix *P*
- VL12 - Mains voltage L1-N, prefix *n*
- VL23 - Mains voltage L2-L3, prefix *P*
- VL23 - Mains voltage L2-N, prefix *n*
- VL31 - Mains voltage L3-L1, prefix *P*
- VL31 - Mains voltage L3-N, prefix *n*
- GEN V. - Generator voltage
- GEN FRG. - Generator frequency (Hz)
- BATTERY - Battery voltage

The **ALARM** LED will flash if the unit detects an engine stopping error. When the DISPLAY MODE (23) button is pressed so as to select this option, the display will show the cause of the error indication. This error message is:

StP.E - Stop Error

The **ALARM** LED will be skipped if there isn't an engine stopping error.

Example 1: Using Alternate Display with Single phase selection

Mains Voltage L1-N

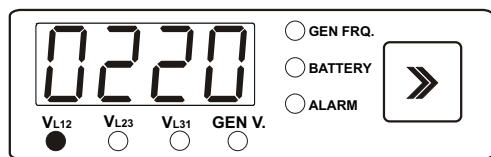

Generator Voltage

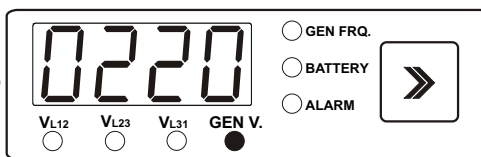

Press the display mode button.

Press the display mode button again.

Generator Frequency (Hz)

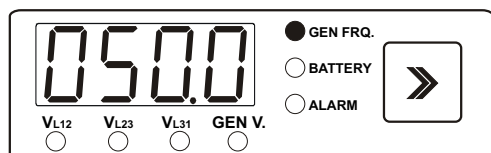

Battery Voltage

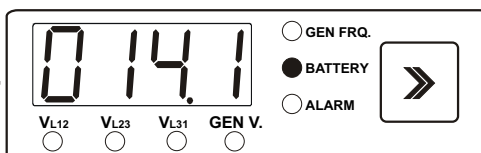

Press the display mode button again.

Press the display mode button again.

Error Message

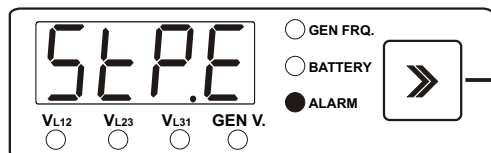

Press the display mode button again.

If engine stopping error is not present when the display mode button is pressed, Error Message screen is skipped.

Mains Voltage L1-N

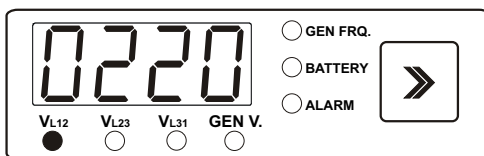

Example 2: Using Alternate Display with Three phase selection

Mains Voltage L1-L2

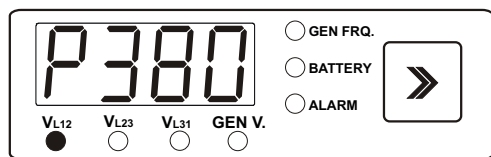

Mains Voltage L1-N

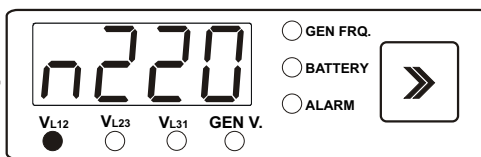

Press the display mode button.

Press the display mode button again.

Mains Voltage L2-L3

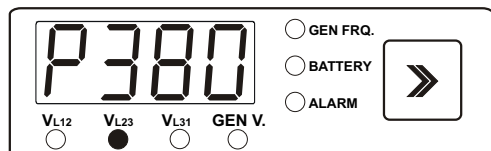

Mains Voltage L2-N

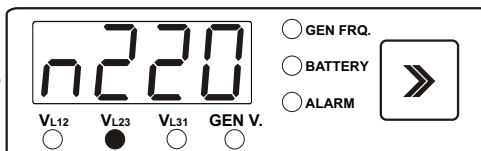

Press the display mode button again.

Press the display mode button again.

Mains Voltage L3-L1

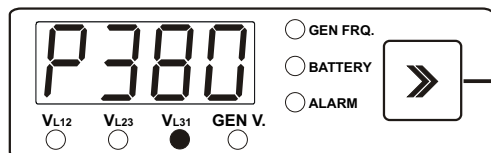

Mains Voltage L3-N

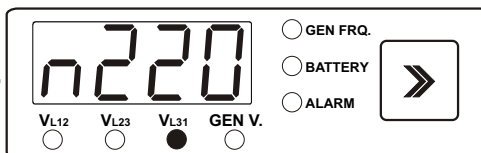

Press the display mode button again.

Press the display mode button again.

Generator Voltage

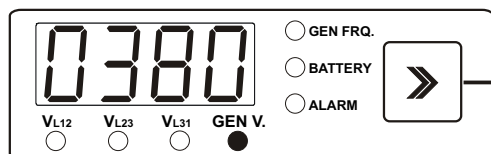

Generator Frequency (Hz)

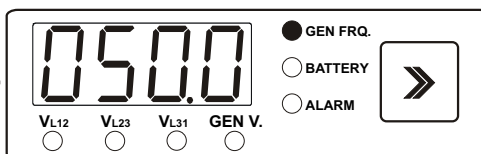

Press the display mode button again.

Press the display mode button again.

Battery Voltage

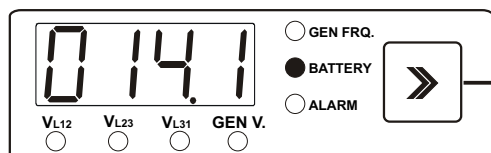

Error Message

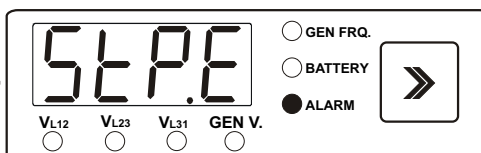

Press the display mode button again.







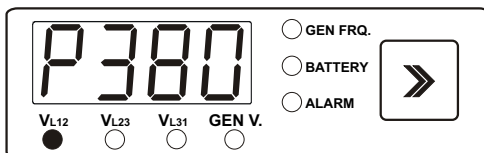







Press the display mode button again.

If engine stopping error is not present when the display mode button is pressed, Error Message screen is skipped.









Mains Voltage L1-L2





6.2 Failure Indicators Description



					Bat.Voltage Failure
					SPARE 1
					SPARE 2

Explanations :

- 1-   (**Start Failure LED**) : The Unit drives to the starter motor according to values determined in P06 and P16. But, starting the engine is not possible in this values the unit gives a Start Failure. In this case the LED flashes and the horn is sounded. The unit must be reset by pressing the RESET (13) button before a fresh attempt can be made.
- 2-   (**High Temperature Failure LED**) : Failure will be active when the High Temperature Switch is which is connected to the Unit via Pin 8 getting excessive hot as result of possible heating of engine. In this case the LED flashes and the Horn is sounded and engine shuts-down without any cool-down period.
- 3-   (**Low Oil Pressure Failure LED**) : The sensor that is connected to the Unit via Pin 7 is Normally Closed. The contact will open when Oil Pressure in the engine reaches to proper level. If the contact will not open the engine is running. In this case the LED flashes and the Horn is sounded and engine shuts-down without any cool-down period.
- 4-   (**Over Speed Failure LED**) : The unit decides to the Over Speed Failure that depending on the values of parameters P05 and P21. At the end of **control on delay** time defined by parameter P19, if the generator speed goes above the **Speed Upper Limit** and continues for of **Speed Fault Control Delay** time period, the LED flashes and the Horn is sounded and engine shuts-down without any cool-down period.

Generator speed is measured from alternator output frequency.

- 5-   (**Generator voltage Failure LED**): The unit decides to the Generator Voltage Failure when the Alternator Voltage is out of the values determined with P03, P04 and P20 parameters. At the end of **control on delay** time defined by parameter P19, if the alternator voltage is out of **Alternator Voltage Lower Limit** or **Alternator Voltage Upper Limit** and continues for of **Alternator Voltage Fault Control Delay** time period, the LED flashes and the Horn is sounded and generator contactor is released if closed, engine shuts-down without any cool-down period.

6-   (**Charge Generator Failure LED**): At the end of **control on delay** time defined by parameter P19, the unit checks + Voltage which comes from Charge Generator via Pin 11. If there is no Voltage the unit decides to Charge Generator Failure. In this case the LED flashes and the Horn is sounded.

7-  **Bat.Voltage Failure** (**Battery Voltage Failure LED**): Battery Voltage Failure is monitored continuously in all modes except "OFF" mode. This failure occurs continuously when the battery voltage falls below the value specified by the **Battery voltage lower limit** parameter P11. In this case the LED flashes and the Horn is sounded. It is self resetting once the fault has been removed.

The EAOM-19 measures battery voltage at the EAOM-19 terminals. Depending on the size and length of the cable to the battery, this may be somewhat less than the voltage as measured at the battery.

8-  **SPARE 1** (**Configurable Failure Input-1 LED**): Configurable Failure-1 input works on value determined in Parameter P22. When the input is active (Pin 9) the unit works according to selection of user.

9-  **SPARE 2** (**Configurable Failure Input-2 LED**): Configurable Failure-2 input works on value determined in Parameter P23. When the input is active (Pin 10) the unit works according to selection of user.

StPE - Stop Error Message (Fail to Engine Stopping):

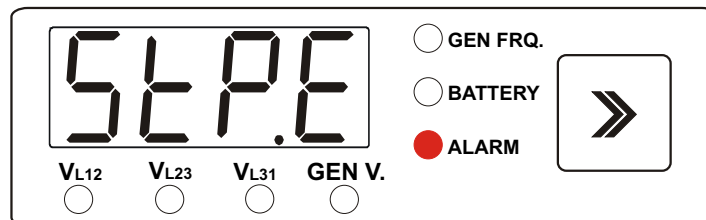

Once the EAOM-19 has given a shutdown signal to the engine it expects the engine to rest. It monitors the **Engine Started Signal** sources and if they still indicate engine movement when **30** seconds time period expires, The **StPE** alarm signal is generated. The  **ALARM** LED will flash continually.

6.3 Mode Transition

The mode can be changed at any time. Any changes between Auto, Manual and Test modes will not effect the current state of the generator or load connection.

6.4 Manual Start

1. Press the MAN ENGINE START (14) button on the panel the LED (3) will light on. The engine should start. The sequence is as follows:

- The starter motor runs
- The engine starts

Once the engine is running,

- Generator will be ready to take the load after "control on delay" time period like as AUTO mode.
- It is not possible supply to load on the generator unless "control on delay" time is elapsed (The contactor open / close button does not work)

2. Once "control on delay" time is elapsed, press the MAINS CONTACTOR OPEN (21) button to disconnect the load from the mains supply. LED (9) should light. LED (4) should go off.

3. Press the GENERATOR CONTACTOR CLOSE (16) button to connect the load to the generator supply. LED (5) should light. LED (10) should go off.

6.5 Manual Stop

The LED (8) is lit and engine is stopped when the MAN ENGINE STOP (20) button is pressed. When the MAN ENGINE STOP (20) button is pressed while the load connected to the generator first generator contactor is released then engine is stopped after a cool down period.

6.6 Auto Operation

Press the AUTO (18) button to select Auto mode. The LED (7) in the corner of the button will light to indicate this mode has been selected.

In the event of a mains voltage failure, the unit will start up the generator and, once the generator is running and alternator voltage available, will transfer the load to the generator. When the mains is restored and stable, it will transfer the load back to the mains and, after a cool-down period, shut down the generator.



6.7 Test Operation

Press the TEST (11) button to select Test mode the LED (1) will light on. This mode allows for testing of the generator off load. All alarm circuits will operate so that any faults will be reported. If a mains failure occurs while the unit is in Test mode, the unit will revert to Auto mode and will switch the load to the generator.

7 Fault Finding

Indicators on the central section of the panel will flash if a fault is detected. *See Section 6.2 Failure Indicators Description.* Fault conditions except Battery Voltage Failure are latched so that further operation is prevented. If a failure is indicated, proceed as follows:

1. Find and fix the fault.
2. Press the RESET (13) button to enable a restart.

In addition to the indicators on the centre panel, the  **ALARM** LED will flash in the event of an engine stopping error. To display the fault message reported by the  **ALARM** LED, press repeatedly DISPLAY MODE (23) button until the **ALARM** option has been selected. If there isn't fault message, the **ALARM** option will be skipped.

Tablo 7.1 Fault Finding

Symptom	Possible Remedy
Unit is in operative	Check the battery and wiring to the unit.
	Check the DC supply. (measure voltage between pins 1 and 2)
	Check the DC fuse.
Low oil pressure fault after engine has started.	Check engine oil level and pressure.
	Check oil pressure switch and wiring.
	Check that oil pressure switch is of the normally closed type (opens on oil pressure).
High engine temperature Fault after engine has started.	Check engine temperature and cooling systems.
	Check switch and wiring.
	Check that temperature switch is of normally open type (closes on high temperature).
Failed to Start fault. Engine failed to start after Pre-set number of Attempts.	Check fuel solenoid and wiring, fuel and battery. Reset the EAOM-19 and restart the engine.
	Check for battery + output at pin 5, (Fuel Solenoid if selected)
	Check the signals that the EAOM-19 is using to determine if the engine has started. Refer to engine manual.
Starter motor inoperative.	Check wiring to starter solenoid.
	Check battery supply.
	Check battery supply is present on the Start output pin 4 of the EAOM-19.



Disconnect the equipment totally from electricity in the best and correct way during mechanical and electrical maintenance. When this is not possible, the equipment must be in the "OFF" position for preventing any accident.

8. Specifications

Equipment Use	: Electrical control equipment for generating sets
Housing & Mounting	: 72mm x 72mm x 95mm. (Including connectors) ¼ DIN43700 plastic housing for panel mounting.
Panel Cut-Out	: 69mm x 69mm.
Protection	: NEMA 4X (Ip65 at front panel, Ip20 at rear side).
Weight	: Approximately 270gr.
Environmental Rating	: Standard, indoor at an altitude of less than 2000 meters with non-condensing humidity.
Operating / Storage Temperature:	-25 C to +70 C / -40 C to +85 C.
Operating / Storage Humidity	: 90 % max. (non-condensing)
Installation Over Voltage	: II Appliances, portable equipment
Category	
Pollution Degree	: II, Normal office or workplace, non conductive pollution.
Mode Of Operation	: Continuous.
DC Battery Voltage Supply	: 8 to 32 V --- , max. operating current is 240 mA.
Cranking Dropouts	: Battery voltage can be "0" Volt for max. 100 ms during cranking (battery voltage should be at least nominal voltage before cranking).
Battery Voltage Measurement	: 8 to 32 V --- , accuracy; 1 % FS, resolution; 0,1 V.
Mains Voltage Measurement	: Selectable three phase or single phase, 4 wire connection for three phase, 2 wire connection for single phase gen-set. 35 to 300 V \sim Ph-N, 15.6 to 99.9 Hz. Accuracy; 1 % FS, Resolution; 1 V.
Generator Voltage Measurement	: 35 to 300 V \sim Ph-N, 15.6 to 99.9 Hz. Accuracy; 1 % FS, Resolution; 1V.
Generator Speed (Frequency)	: 15.6 to 99.9 Hz. (min 35 V \sim Ph-N) Accuracy; 0,25 % FS, Resolution; 0,1 Hz.
Charge Generator Excitation	: 220 mA, max 4W.
Contact Sensing Inputs	: Oil Pressure Switch (NC) Temperature Switch (NO) Configurable Input-1 (NO) Configurable Input-2 (NO)
Relay Outputs	: Start relay (1NO. 16A@32V ---) Fuel relay (1NO. 16A@32V ---) Horn relay (1NO. 16A@32V ---) Mains contactor relay (1NC. 5A@250V \sim) Generator contactor relay (1NO. 5A@250V \sim)

Display : 4 digits, 7 segments, LED display showing;
Mains voltage (Ph-Ph or Ph-N)
Alternator voltage (u only)
Alternator frequency
Battery voltage
Program parameters

Failure Indicators : Start failure LED
High temperature LED
Low oil pressure LED
Over speed LED
Generator voltage failure LED
Charge generator failure LED
Battery voltage failure LED
Configurable input-1 LED
Configurable input-2 LED

Status Indicators : TEST mode LED
PROG mode LED
OFF mode LED
AUTOMATIC mode LED
Man Engine Start LED
Man Engine Stop LED
Mains contactor open LED
Generator contactor open LED
Mains contactor close LED
Generator contactor close LED
Generator voltage okay LED
Mains voltage okay LED

9. Block Diagram

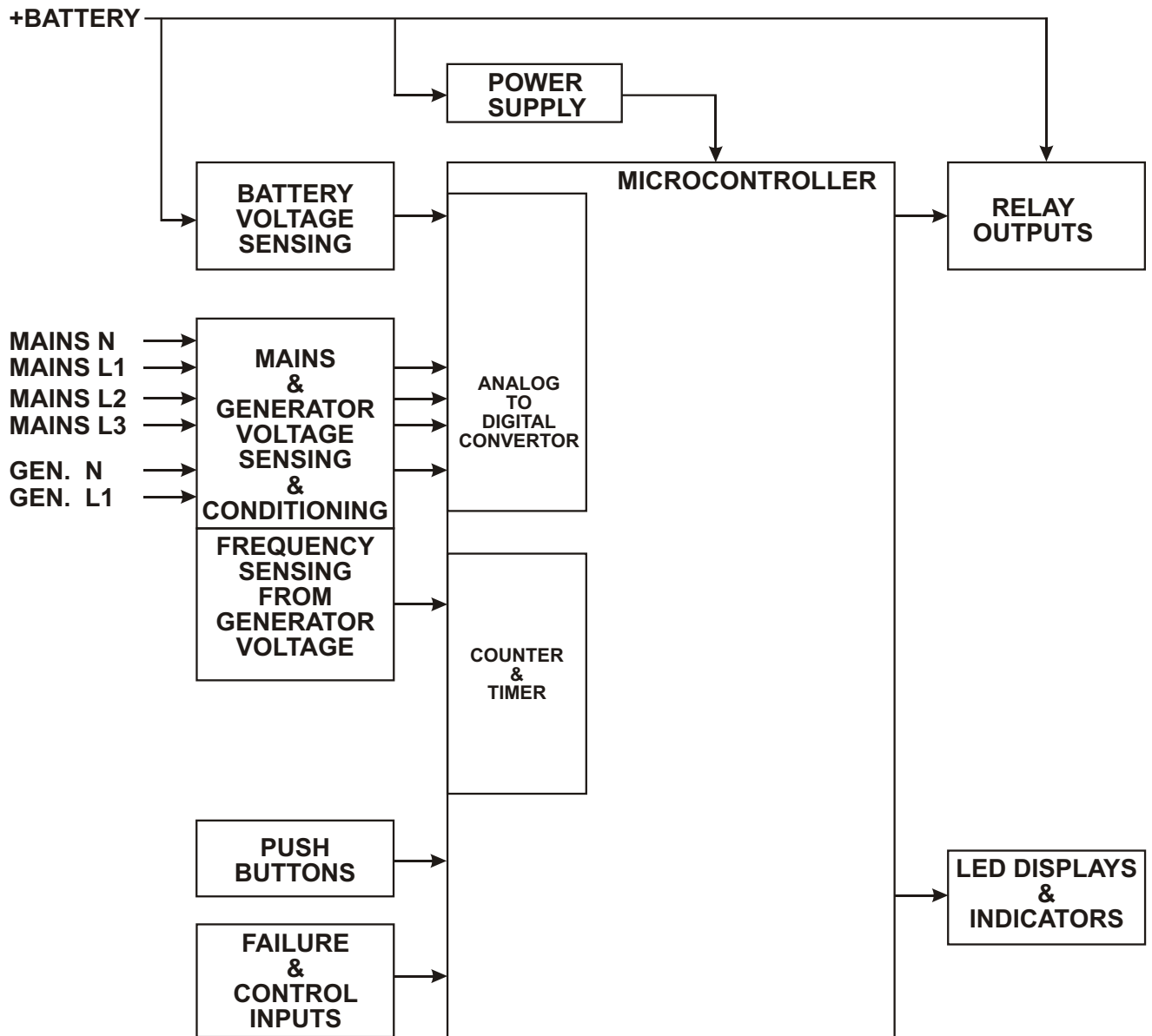

EAOM-19 BLOCK DIAGRAM

10. User Defined Parameters

List - 1

Prm. No.	Definition of Parameter	User Defined Value
P00	Mains voltage connection level	
P01	Mains voltage disconnection level	
P02	Mains voltage upper limit	
P03	Alternator voltage lower limit	
P04	Alternator voltage upper limit	
P05	Speed upper limit	
P06	Number of starting attempts	
P07	Engine cooling time	
P08	Horn duration	
P09	Mains transition delay	
P10	Single / Three phase selection	
P11	Battery voltage lower limit	
P12	Mains-Generator or Generator-Mains change over delay	
P13	Stop / Fuel solenoid selection	
P14	Stop magnet energising time	
P15	Engine started signal	
	P15.0 Charge generator	
	P15.1 Speed	
	P15.2 Alternator voltage	
	P15.3 Oil pressure	
P16	Starting attempt duration	
P17	Alternator voltage limit for crank disconnection	
P18	Speed limit for crank disconnection	
P19	Control on delay	
P20	Alternator voltage fault control delay	
P21	Speed fault control delay	
P22	Spare input-1 (Pin9)	
P23	Spare input-2 (Pin10)	
P24	Horn output selection	
P25	Choke time	
P26	Generator start delay	
P27	Oil sensor selection	
P28	Operator password (P00 to P09, and P28)	
P29	Technician password (P00 to P29)	

Change Date : / /

Change Technician Name :